

This document is made available through the declassification efforts
and research of John Greenewald, Jr., creator of:

The Black Vault



The Black Vault is the largest online Freedom of Information Act (FOIA) document clearinghouse in the world. The research efforts here are responsible for the declassification of hundreds of thousands of pages released by the U.S. Government & Military.

Discover the Truth at: <http://www.theblackvault.com>

UNCLASSIFIED INTERNAL USE ONLY CONFIDENTIAL SECRET

ROUTING AND RECORD SHEET

SUBJECT: (Optional)				
FROM:		EXTENSION	NO	
C/TSD/EB			DATE 24 June 1964	
TO: (Officer designation, room number, and building)	DATE		OFFICER'S INITIALS	COMMENTS (Number each comment to show from whom to whom. Draw a line across column after each comment.)
	RECEIVED	FORWARDED		
1. C/WH/SA/MOB/PM GH4408 Hdqrs.			<i>C/S</i>	<p>Bushnell 1.3 X phantom scopes are made in Japan - w/w distributor all have English marking</p> <p>2 to 2: 2 hrs attached copy this in for your attention.</p> <p>file successful seems like a touch job trus. (u)</p>
2. <i>NA/SI/SC/NS</i>			<i>NS</i>	
3. <i>W/SA/ECB</i>			<i>W</i>	
4. <i>Clatter</i>				
5.				
6.				
7.				
8.				
9.				
10.				
11.				
12.				
13.				
14.				
15.				

SECRET

24 June 1964

MEMORANDUM FOR: C/WH/SA/MOB/PM

SUBJECT : Improved Sight for 7.62 Belgium (FAL) Rifle

REFERENCE : a) Memo for the Rcd. dated 25 May 64,
Subject: "FAL Silencer/Sights", from
C/WH/SA/MOB/PM

1. In accordance with reference a) the following material is provided:

- a) Three open rear sight hoods for the subject rifle.
- b) Three copies of instructions for installing the sight and zeroing the rifle.
- c) Three tool kits containing an adjustment screw driver and two files.
- d) 400 rounds of improved underloaded ammunition with cream of wheat filler. (Boxes marked with red strip. These should be substituted for the rounds already delivered).

2. It must be understood that the limited time available would not permit more than cursory acceptance testing and the superiority of this sight over the standard unit has not been definitely established.

3. The scope and mount requested in reference a) proved to be an unfeasible development in the time available. A mount could not be devised which was interchangeable with any FAL without extensive modification to the weapon.

4. For additional information regarding this matter contact or on extension 3319.

Chief
TSD/Engineering Branch

Attachments: As Stated

Distribution:
1 - Addressee
1 - TSD/SDB
1 - C/TSD
1 - EB-81J

SECRET

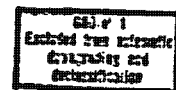

**SNAP-ON SIGHT HOOD FOR
THE 7.62 BELGIUM (FAL) RIFLE**

1. The sight hood snaps over the existing rear sight on the 7.62 Belgium (FAL) rifle. It is designed to raise the rear sight to compensate for the more curving trajectory of the underloaded ammunition and is an open sight for increased night sighting capability.

2. The sight hood is oriented with the three screws facing the muzzle end of the rifle (See attached drawings). Press down on the hood until the ball detent snaps into the peep hole

3. The slot for the existing rear sight is made tight so that the hood will fit firmly in place. If it fails to fit, file the existing rear sight as necessary. If the sight fits the slot but is difficult to snap on and off, or is too loose, adjust the ball detent by turning the center set screw on the sight hood.

4. The weapon must be zeroed on a known distance firing range to determine the sight settings and proper sight picture for standard and underloaded ammunition when using the hood. The only adjustments possible are those already on the rifle. (That is, elevation control using the graduated ramp and windage control by adjustment of the two locking screws at the base of the existing rear sight dovetail.)

NOTE: It is very important to hold the rifle the same way each time so that the relation of the eye to the rear sight remains constant. The user must determine his own zero for each rifle and hood combination and maximum effective range for each ammunition type.

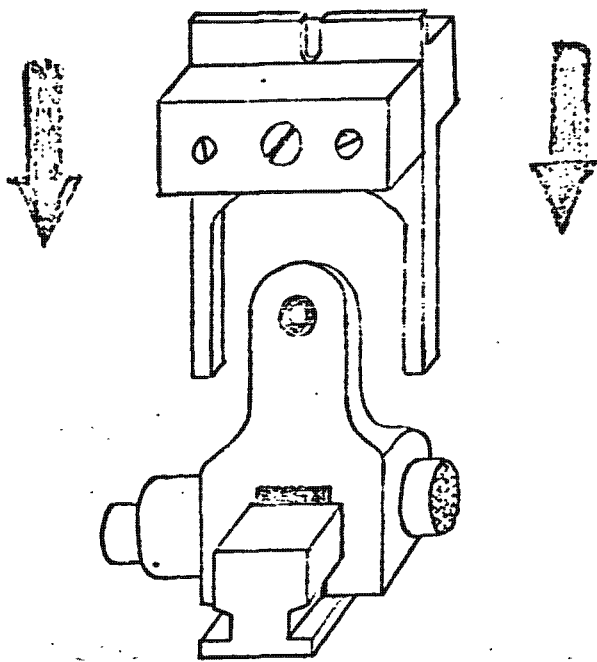

FRONT VIEW

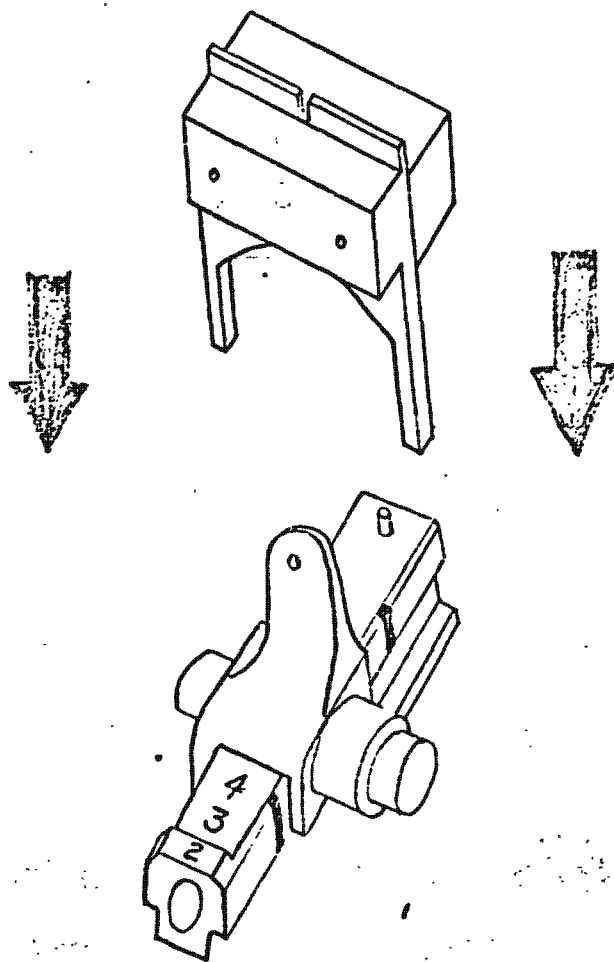

REAR VIEW